

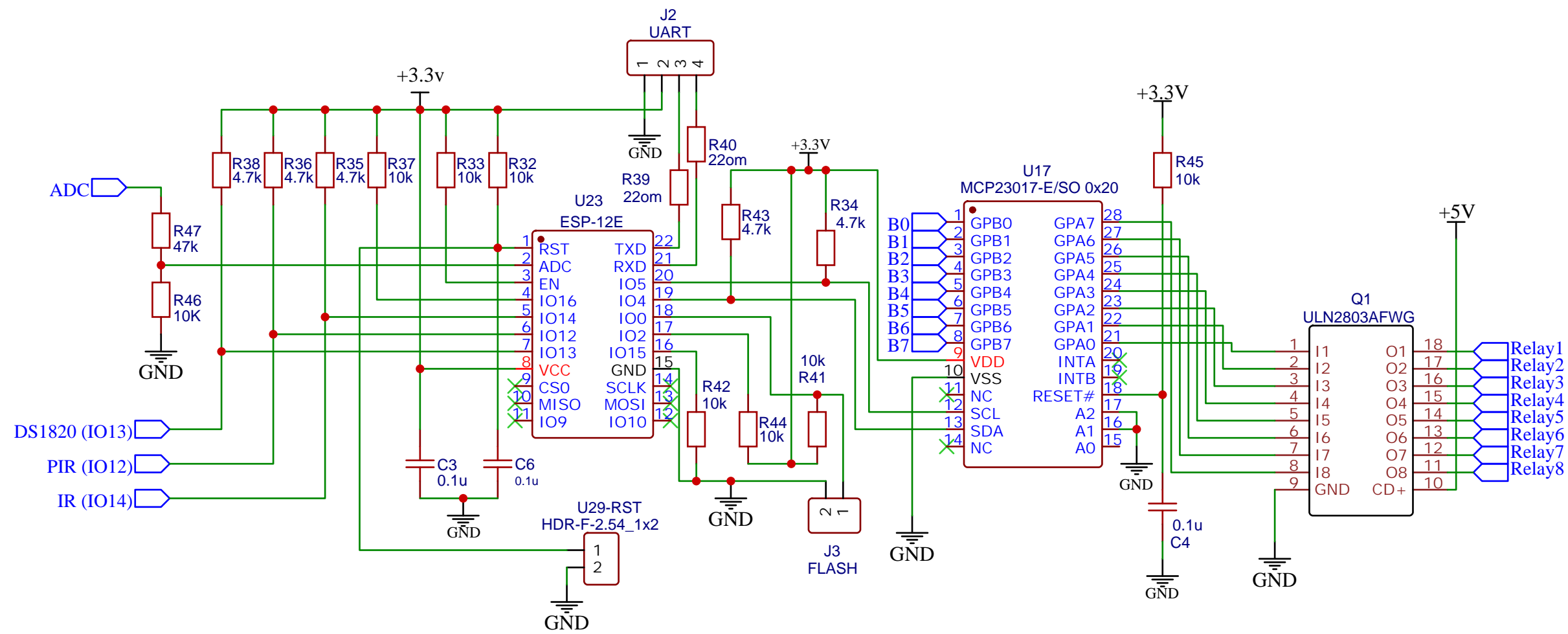

TITLE: Sheet_1		REV: 1.0
	Company: Your Company	Sheet: 1/1
	Date: 2021-02-03 Drawn By: Romik4x4	



TITLE: Sheet_2		REV: 1.0
	Company: Your Company	Sheet: 1/1
	Date: 2021-02-09	Drawn By: Romik4x4

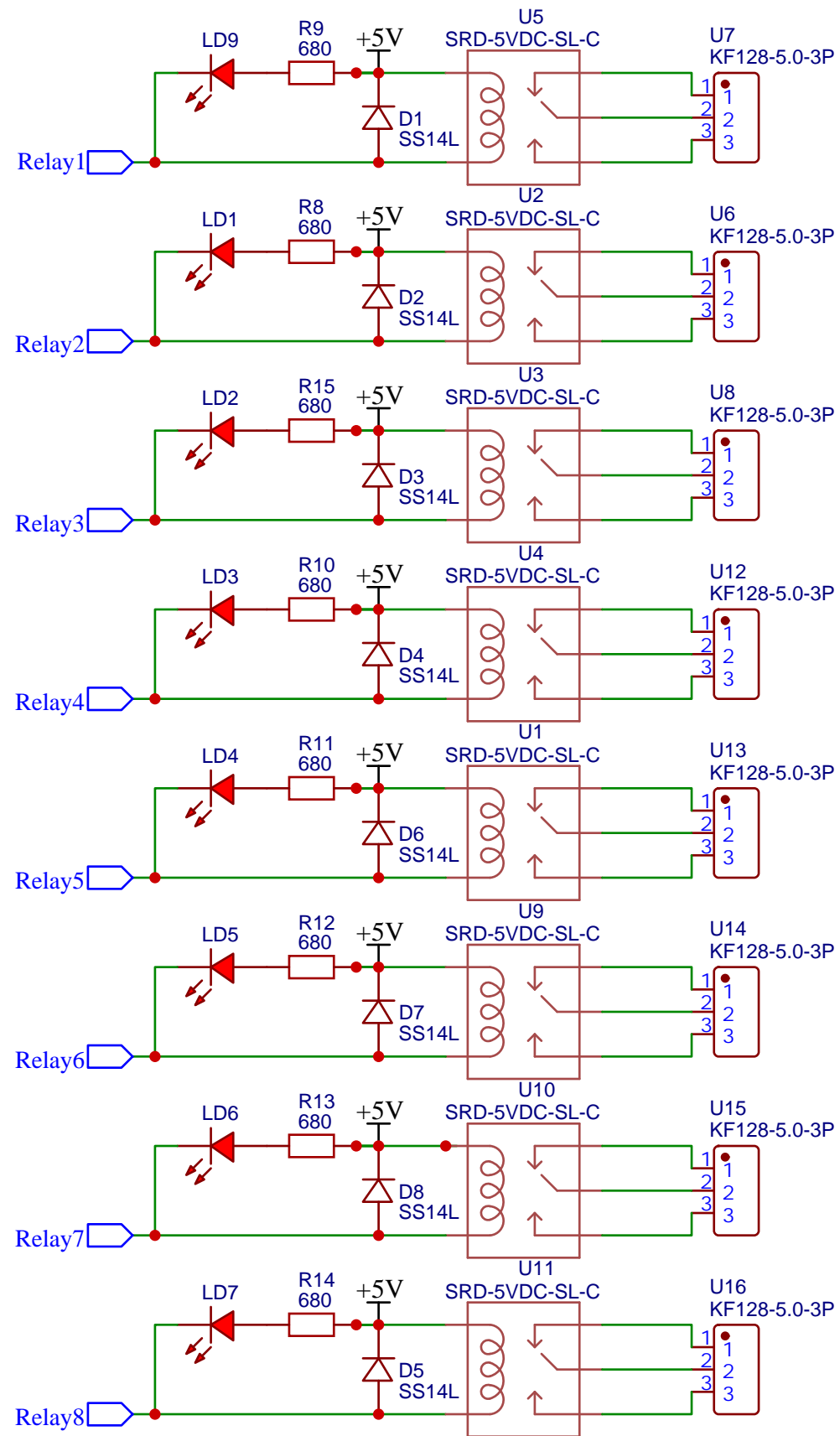

TITLE: Sheet_3		REV: 1.0
	Company: Your Company	Sheet: 1/1
	Date: 2021-02-09	Drawn By: Romik4x4

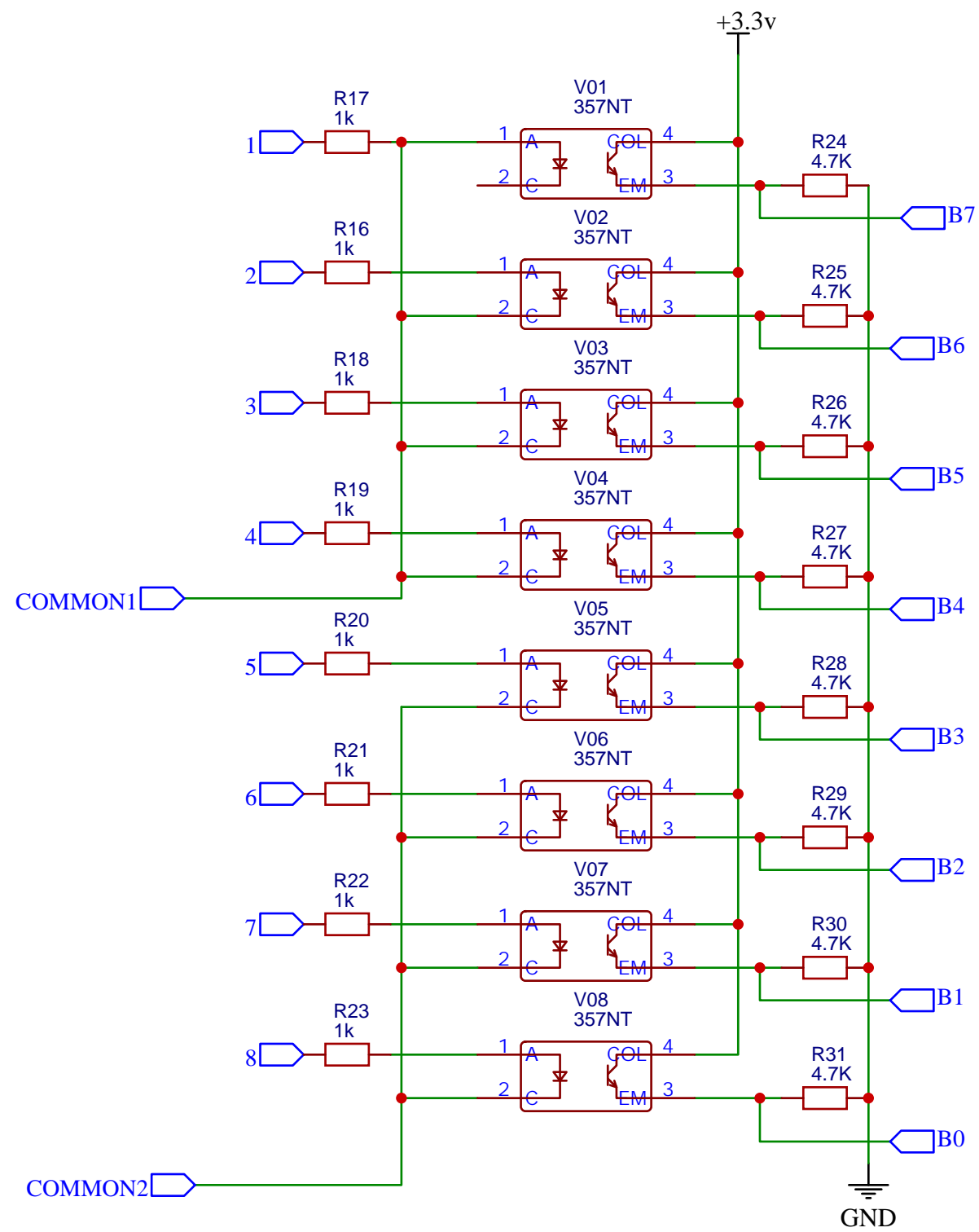

TITLE: Sheet_4		REV: 1.0
	Company: Your Company	Sheet: 1/1
	Date: 2021-02-09	Drawn By: Romik4x4

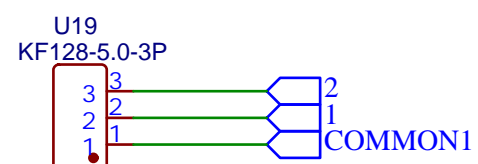
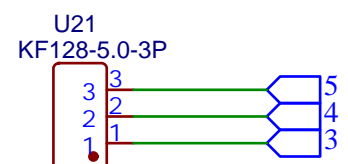
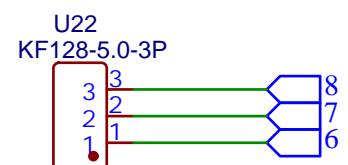
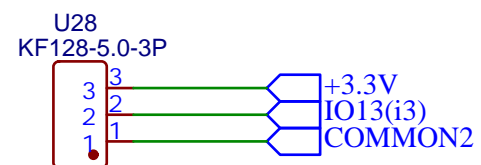
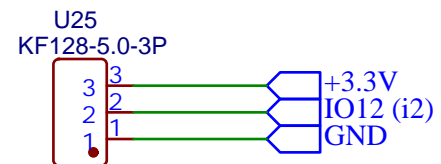
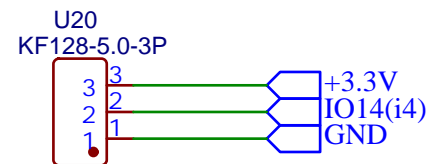
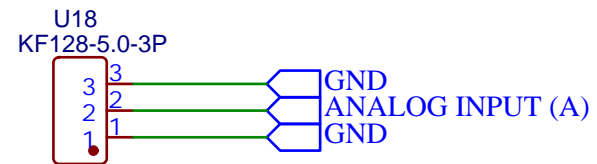
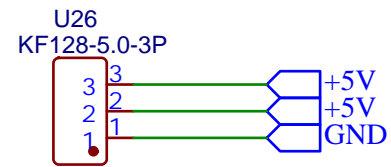

TITLE: Sheet_5		REV: 1.0
	Company: Your Company	Sheet: 1/1
	Date: 2021-03-01 Drawn By: Romik4x4	